



Bid Bulletin No. 1
28 August 2019

PUBLIC BIDDING NO. 19-266-5

**Supply and Delivery of Various Furniture and Fixtures
for the Bureau of Quarantine (BOQ)**

Issued pursuant to Sec. 22.5 of the IRR of R.A. 9184 to clarify and/or amend certain provisions in the Bidding Documents issued for this project, considering the issues raised and clarifications made by prospective bidders during the **Pre-Bid Conference** held on **August 23, 2019**, likewise, respond to bidders' written queries received within the prescriptive period for filing.

A. AMENDMENTS

SECTION VII. TECHNICAL SPECIFICATIONS	
<p>Item No. 1: CONFERENCE TABLE</p> <p>Page 74</p> <p>xxx</p> <ul style="list-style-type: none"><u>Color of legs: Beige / Light gray</u> <p><u>NOTE: The winning bidder shall submit a sample shade of color or finish before the delivery of item subject to approval of the end-user.</u></p> <p>Item No. 2: CUSTOMIZED WRITING TABLE</p> <p>Page 76</p> <p>xxx</p> <p><u>NOTE: The winning bidder shall submit a sample shade of color or finish before the delivery of item subject to approval of the end-user.</u></p> <p>Item No. 3: JUNIOR EXECUTIVE TABLE</p> <p>Page 79</p> <p>xxx</p> <ul style="list-style-type: none"><u>Color: Beige / Off-white / Light gray</u>	<p>To clarify the requirements for better understanding.</p>

For the purpose of this Bulletin and for better understanding of its contents, the following rules shall apply: (a) ~~Double Strike out~~ – denotes deletion; (b) Underline – denotes inclusion or new item/requirement; and "xxx" – denotes separation of phrase/s being amended from the rest of the main text.

- Color of legs: Beige / Off-white / Light gray
 - Table top shall be laminated finish with laminated edges / pvc edge banding wrapped around the edges
- NOTE: The winning bidder shall submit a sample shade of color or finish before the delivery of item subject to approval of the end-user.

Item No. 4: SENIOR EXECUTIVE TABLE

Page 81

xxx

- Color: Beige / Off-white / Light gray
 - Color of legs: Beige / Off-white / Light gray
 - Table top shall be laminated finish with laminated edges / pvc edge banding wrapped around the edges
- NOTE: The winning bidder shall submit a sample shade of color or finish before the delivery of item subject to approval of the end-user.

Item No. 5: JUNIOR EXECUTIVE CHAIR

Page 83

xxx

- Back Rest: ~~Mesh~~ Leatherette
 - Seat Rest: ~~Fabric~~ Leatherette, black
- NOTE: The winning bidder shall submit a sample shade of color or finish before the delivery of item subject to approval of the end-user.

Item No. 6: SENIOR EXECUTIVE CHAIR

Page 85

xxx

- Back Rest: High Back ~~Mesh~~ Leatherette Chair
- NOTE: The winning bidder shall submit a sample shade of color or finish before the delivery of item subject to approval of the end-user.

Item No. 8: HORIZONTAL FILING CABINET

Page 89

xxx

NOTE: The winning bidder shall submit a sample shade of color or finish before the delivery of item subject to approval of the end-user.

Item No. 9: FIVE (5) DRAWER LATERAL FILE CABINET

Page 91

xxx

- **Color: beige or Light gray**
- **Handle: Flush recessed**

NOTE: The winning bidder shall submit a sample shade of color or finish before the delivery of item subject to approval of the end-user.

Item No. 10: SIX DOOR LOCKER

Page 93

xxx

- **Color: Off white or Light gray**

NOTE: The winning bidder shall submit a sample shade of color or finish before the delivery of item subject to approval of the end-user.

Item No. 11: STEEL CABINET

Page 95

xxx

- **Enamel painted or powder coated finish still with the same color and material**

NOTE: The winning bidder shall submit a sample shade of color or finish before the delivery of item subject to approval of the end-user.

Item No. 12: THREE (3) DRAWER LATERAL FILE CABINET

Page 97

xxx

- **Color: beige or Light gray**
- **Handle: Flush recessed**

NOTE: The winning bidder shall submit a sample shade of color or finish before the delivery of item subject to approval of the end-user.

Item No. 13: MOBILE PEDESTAL

Page 99

xxx

- **Dimensions: (W) 40cm x (H) 64.5cm x (D) 55.5cm with tolerance of (±1cm) in all dimensions**

NOTE: The winning bidder shall submit a sample shade of color or finish before the delivery of item subject to approval of the end-user.

Item No. 14: THREE (3) SEATER OFFICE SOFA

Page 101

xxx

NOTE: The winning bidder shall submit a sample shade of color or finish before the delivery of item subject to approval of the end-user.

B. CLARIFICATIONS

The Department of Budget and Management - Procurement Service, Bids and Awards Committee hereby clarifies prospective bidders' concerns and queries:

ITEM	CONCERN	REFERENCE	CLARIFICATION/ RESOLUTION
1. Cubix Office Inc. ¹			
1	Request to include the Light gray Color of legs	Section VII. Technical Specifications Item No. 1: CONFERENCE TABLE Pages 74 xxx The color of legs is not specified xxx	<i>Please see above amendments.</i>

¹ Letter received on 24 August 2019

2	Request to include the Light gray Color of legs and to specify the top finish is postform	Section VII. Technical Specifications Item No. 3: JUNIOR EXECUTIVE TABLE Pages 79 xxx The color of legs is not specified xxx	<i>Please see above amendments.</i>
3	Request to include the Light gray Color of legs and to specify the top finish is postform	Section VII. Technical Specifications Item No. 4: SENIOR EXECUTIVE TABLE Pages 81 xxx Color: Beige or off-white xxx	<i>Please see above amendments.</i>
4	Request to attached any design picture base on the specification.	Section VII. Technical Specifications Item No. 5: JUNIOR EXECUTIVE CHAIR Pages 83 xxx xxx	<i>The design of chair may not be exactly as shown in the picture but must comply with the specifications.</i>
5	Request to change the Back Rest Mesh to Leatherette finish and attached any design picture base on the specification	Section VII. Technical Specifications Item No. 6: SENIOR EXECUTIVE CHAIR Pages 85 xxx Back Rest: High Back Mesh Chair xxx	<i>Please see above amendments.</i> <i>The design of chair may not be exactly as shown in the picture but must comply with the specifications.</i>
6	Proposed to consider Light gray and to include what kind of handle	Section VII. Technical Specifications Item No. 9: FIVE (5) DRAWER LATERAL FILE CABINET Pages 91 xxx Color: Beige xxx	<i>Please see above amendments.</i>
7	Proposed to consider Light Gray	Section VII. Technical Specifications Item No. 10: SIX DOOR LOCKER Pages 93 xxx Color: Off white xxx	<i>Please see above amendments.</i>
8	Request to change the Enamel Painted to Powder Coated Finish Light Gray and to increase the ABC since the ABC is low for gauge 20	Section VII. Technical Specifications Item No. 11: STEEL CABINET Pages 95 xxx Enamel Painted xxx	<i>Please see above amendments.</i> <i>The original requirement is retained.</i>

9	Proposed to consider Light Gray	Section VII. Technical Specifications Item No. 12: THREE (3) DRAWER LATERAL FILE CABINET Pages 85 xxx Color: Beige xxx	<i>Please see above amendments.</i>
---	--	--	-------------------------------------

All other portions of the Bidding Documents affected by these amendments shall be made to conform to the same.

Amendments/inclusions/clarifications made herein shall be considered an integral part of the Bidding Documents.

(sgd)
WEBSTER M. LAUREÑANA
Chairperson, Bids and Awards Committee V

NOTE: The winning bidder shall submit a sample shade of color or finish before the delivery of item subject to approval of the end-user.

I hereby certify that the statement of compliance to the foregoing technical specifications are true and correct, otherwise, if found to be false either during bid evaluation or post-qualification, the same shall give rise to automatic disqualification of our bid.

Name of Company /
Bidder

Signature Over Printed
Name of Authorized
Representative

Date



ITEM NO. 2 : CUSTOMIZED WRITING TABLE

QUANTITY : 11 units (6 units – Silver Gray; 5 units – Vibrant Yellow)

ABC / UNIT : Php 45,000.00

ABC FOR THE ITEM : Php 495,000.00

AGENCY'S SPECIFICATIONS	BIDDER'S STATEMENT OF COMPLIANCE	REFERENCE/ PRODUCTION LAY-OUT
<ul style="list-style-type: none"> • Counter Top 		
<ul style="list-style-type: none"> - Material: Synthetic Granite Countertop 		
<ul style="list-style-type: none"> - Dimensions: (L) 2300mm x (W) 610mm x (H) 50mm with tolerance of (±10mm) in all dimensions 		
<ul style="list-style-type: none"> - Color: Black 		
<ul style="list-style-type: none"> • Stand 		
<ul style="list-style-type: none"> - Material: double-¾ inch thick Marine Plywood on Ducco Paint finish 		
<ul style="list-style-type: none"> - Dimensions: (L) 36mm x (W) 510mm x (H) 1100mm with tolerance of (±10mm) in all dimensions 		
<ul style="list-style-type: none"> - Color: Vibrant Yellow for 5 tables, silver gray for 6 tables 		
<ul style="list-style-type: none"> • Shelves 		
<ul style="list-style-type: none"> - Material: single-¾ inch thk Marine Plywood on Ducco Paint finish 		
<ul style="list-style-type: none"> - Dimensions: (L) 2200mm x (W) 510mm x (H) 200mm with tolerance of (±10mm) in all dimensions 		
<ul style="list-style-type: none"> - Color: Vibrant Yellow for 5 tables, silver gray for 6 tables 		
<ul style="list-style-type: none"> • Partition 		
<ul style="list-style-type: none"> - Material: single-¾ inch thk Marine Plywood on Ducco Paint finish 		
<ul style="list-style-type: none"> - Dimensions: (L) 2200mm x (W) 18mm x (H) 500mm with tolerance of (±10mm) in all dimensions 		

- Color: Vibrant Yellow for 5 tables, silver gray for 6 tables		
• Accessories		
- Three (3) sets of ball pen and ball pen holder		
- Four (4) pieces adjustable glider		
• Warranty: One year warranty on parts and service		
• Printing of the DOH and BOQ logo on both sides of the customized writing table in a white vinyl sticker. Each logo is 300mm in diameter and 700mm in length.		

NOTE: The winning bidder shall submit a sample shade of color or finish before the delivery of item subject to approval of the end-user.

I hereby certify that the statement of compliance to the foregoing technical specifications are true and correct, otherwise, if found to be false either during bid evaluation or post-qualification, the same shall give rise to automatic disqualification of our bid.

Name of Company / Bidder

Signature Over Printed Name of Authorized Representative

Date

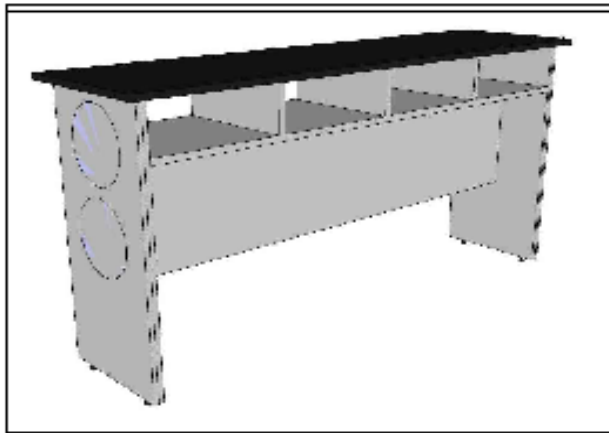

SILVER GRAY DESK

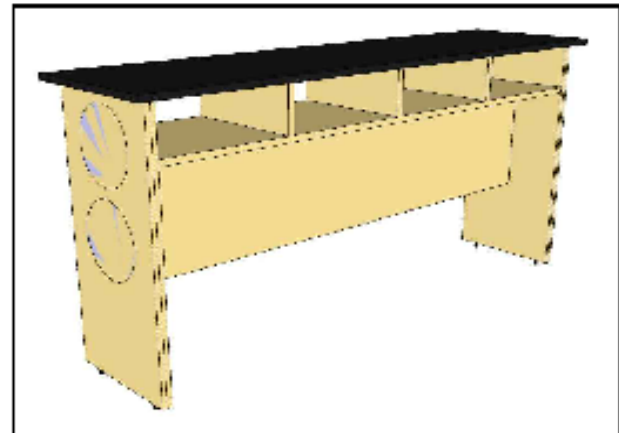

VIBRANT YELLOW DESK

PERSPECTIVE (2)

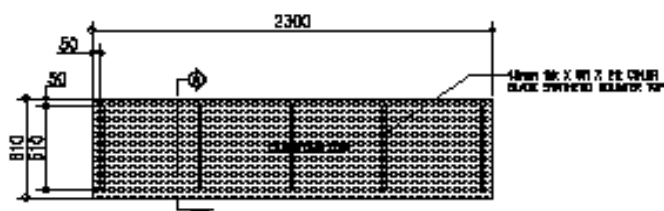

WRITING DECK COUNTERTOP PLAN
SCALE: 1:20 METERS

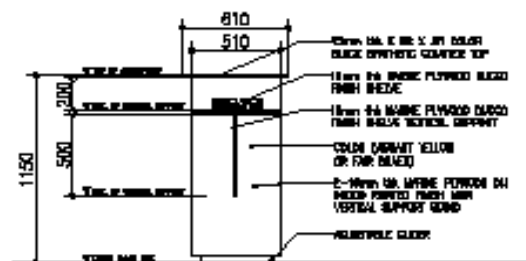

WRITING DECK SECTION THRU "A"
SCALE: 1:20 METERS



WRITING DECK SIDE ELEVATION
SCALE: 1:20 METERS

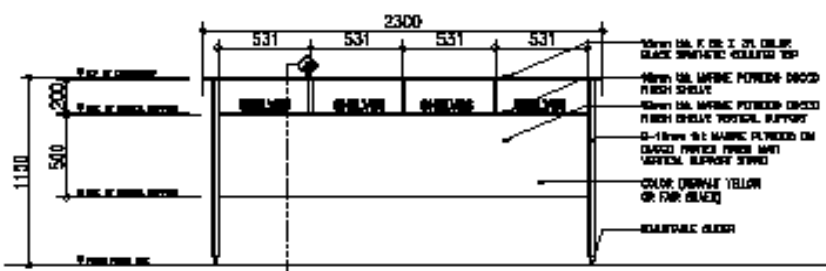

WRITING DECK FRONT ELEVATION
SCALE: 1:20 METERS

ITEM NO. 3 : JUNIOR EXECUTIVE TABLE

QUANTITY : 26 units

ABC / UNIT : Php 5,500.00

ABC FOR THE ITEM : Php 143,000.00

AGENCY'S SPECIFICATIONS	BIDDER'S STATEMENT OF COMPLIANCE	REFERENCE
Brand and Model:		
• Freestanding Table		
• Woodgrain laminated top (beige), 30mm thick with tolerance of (± 2 mm)		
• Powder coated steel legs and panel		
• Color: Beige / Off-white / Light gray		
• Color of legs: Beige / Off-white / Light gray		
• Dimensions: (W) 120cm x (D) 70cm x (H) 75cm with tolerance of (± 2 cm) in all dimensions		
• With two wire management hole for cables and wires on two sides		
• Table Top Thickness: One (1) inch with flat and laminated edges		
• Table top shall be laminated finish with laminated edges / pvc edge banding wrapped around the edges		
• Warranty: One year warranty on parts and service		

NOTE: The winning bidder shall submit a sample shade of color or finish before the delivery of item subject to approval of the end-user.

I hereby certify that the statement of compliance to the foregoing technical specifications are true and correct, otherwise, if found to be false either during bid evaluation or post-qualification, the same shall give rise to automatic disqualification of our bid.

Name of Company /
Bidder

Signature Over Printed
Name of Authorized
Representative

Date



ITEM NO. 4 : SENIOR EXECUTIVE TABLE

QUANTITY : 24 units

ABC/ UNIT : Php 6,500.00

ABC FOR THE ITEM : Php 156,000.00

AGENCY'S SPECIFICATIONS	BIDDER'S STATEMENT OF COMPLIANCE	REFERENCE
Brand and Model:		
• Dimensions: 150 cm. (W) x 70 cm. (D) x 75 cm. (H) with tolerance of (±2 cm.) in all dimensions		
• Color: Beige / Off-white / Light gray		
• Color of legs: Beige / Off-white / Light gray		
• Freestanding Table		
• Tabletop: Melamine finish chipboard (MCF)		
• Table Top Thickness: One (1) inch with flat and laminated edges		
• Table top shall be laminated finish with laminated edges / pvc edge banding wrapped around the edges		
• Powder coated steel legs and panel		
• With two wire management hole for cables and wires on two sides		
• With glider		
• Warranty: One year warranty on parts and service		

NOTE: The winning bidder shall submit a sample shade of color or finish before the delivery of item subject to approval of the end-user.

I hereby certify that the statement of compliance to the foregoing technical specifications are true and correct, otherwise, if found to be false either during bid evaluation or post-qualification, the same shall give rise to automatic disqualification of our bid.

Name of Company /
Bidder

Signature Over Printed
Name of Authorized
Representative

Date



ITEM NO. 5 : JUNIOR EXECUTIVE CHAIR

QUANTITY : 26 units

ABC / UNIT : Php 3,200.00

ABC FOR THE ITEM : Php 83,200.00

AGENCY'S SPECIFICATIONS	BIDDER'S STATEMENT OF COMPLIANCE	REFERENCE
Brand and Model:		
• Back Rest: Leatherette		
• Seat Rest: Leatherette, black		
• PVC Armrest		
• Five (5) stroke base, chrome leg		
• Accessories: Gas lift and caster wheel		
• Warranty: One year warranty on parts and service		

NOTE: The winning bidder shall submit a sample shade of color or finish before the delivery of item subject to approval of the end-user.

I hereby certify that the statement of compliance to the foregoing technical specifications are true and correct, otherwise, if found to be false either during bid evaluation or post-qualification, the same shall give rise to automatic disqualification of our bid.

Name of Company /
Bidder

Signature Over Printed
Name of Authorized
Representative

Date



ITEM NO. 6 : SENIOR EXECUTIVE CHAIR

QUANTITY : 24 units

ABC / UNIT : Php 5,000.00

ABC FOR THE ITEM : Php 120,000.00

AGENCY'S SPECIFICATIONS	BIDDER'S STATEMENT OF COMPLIANCE	REFERENCE
Brand and Model:		
• Back Rest: High Back Leatherette Chair		
• Seat rest: Leatherette		
• With armrest		
• Color: Black		
• Five (5) stroke base, chrome leg		
• Accessories: Gas lift, caster wheels		
• Warranty: One year warranty on parts and service		

NOTE: The winning bidder shall submit a sample shade of color or finish before the delivery of item subject to approval of the end-user.

I hereby certify that the statement of compliance to the foregoing technical specifications are true and correct, otherwise, if found to be false either during bid evaluation or post-qualification, the same shall give rise to automatic disqualification of our bid.

Name of Company /
Bidder

Signature Over Printed
Name of Authorized
Representative

Date



ITEM NO. 7 : GLASS DISPLAY CABINET

QUANTITY : 7 units

ABC / UNIT : Php 17,307.00

ABC FOR THE ITEM : Php 121,149.00

AGENCY'S SPECIFICATIONS	BIDDER'S STATEMENT OF COMPLIANCE	REFERENCE
Brand and Model:		
• Dimensions: 20" L x 15" W x 71" H with tolerance of (±2") in all dimensions		
• Top surface and bottom material: Wood or particle board, 4.25" (±0.25") thick each for top and bottom, white		
• Four (4) – layer glass shelves		
• Swing type Glass door with Lock set		
• Frameless		
• All glass materials should be at least ½" thick with tolerance of (±1/8")		
• Without wheels		
• Installed with LED lights – Four (4) top lights and Six (6) side lights (bottom to 3rd layer)		
• Warranty: One year warranty on parts and service		

I hereby certify that the statement of compliance to the foregoing technical specifications are true and correct, otherwise, if found to be false either during bid evaluation or post-qualification, the same shall give rise to automatic disqualification of our bid.

Name of Company / Bidder

Signature Over Printed Name of Authorized Representative

Date

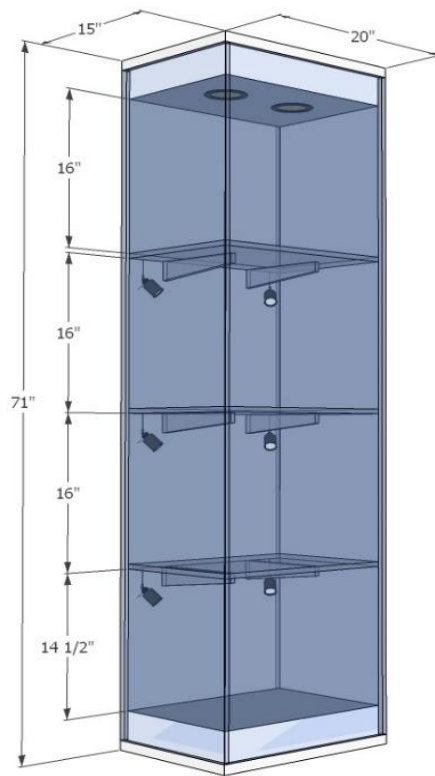

ITEM NO. 8 : HORIZONTAL FILING CABINET

QUANTITY : 9 units

ABC / UNIT : Php 16,500.00

ABC FOR THE ITEM : Php 148,500.00

AGENCY'S SPECIFICATIONS	BIDDER'S STATEMENT OF COMPLIANCE	REFERENCE
Brand and Model:		
• Dimension: 18.25" D x 42" W x 65" H with tolerance of (±2") in all dimensions		
• Color: beige		
• Three (3) Open shelves at the top with the following dimensions: 45cm Depth x 90cm Length x 35.4cm Height with tolerance of (±2cm) in all dimensions		
• Two (2) drawers at the bottom with the following dimensions: 45cm Dep with tolerance of th x 90cm Length x 37cm Height (±2cm) in all dimensions		
• At least ¾" thick particle board with laminate		
• Warranty: One year warranty on parts and service		

NOTE: The winning bidder shall submit a sample shade of color or finish before the delivery of item subject to approval of the end-user.

I hereby certify that the statement of compliance to the foregoing technical specifications are true and correct, otherwise, if found to be false either during bid evaluation or post-qualification, the same shall give rise to automatic disqualification of our bid.

Name of Company /
Bidder

Signature Over Printed
Name of Authorized
Representative

Date



ITEM NO. 9 : FIVE (5) DRAWER LATERAL FILE CABINET

QUANTITY : 7 units

ABC / UNIT : Php 20,000.00

ABC FOR THE ITEM : Php 140,000.00

AGENCY'S SPECIFICATIONS	BIDDER'S STATEMENT OF COMPLIANCE	REFERENCE
Brand and Model:		
• Dimension: 67" H x 42" W x 19" D with tolerance of (±2") in all dimensions		
• Five (5) drawers with centralized lock		
• Color: Beige or Light Gray		
• Powder coated finish		
• Steel plate, at least Gauge 20		
• Handle: Flush recessed		
• Warranty: One year warranty on parts and service		

NOTE: The winning bidder shall submit a sample shade of color or finish before the delivery of item subject to approval of the end-user.

I hereby certify that the statement of compliance to the foregoing technical specifications are true and correct, otherwise, if found to be false either during bid evaluation or post-qualification, the same shall give rise to automatic disqualification of our bid.

Name of Company /
Bidder

Signature Over Printed
Name of Authorized
Representative

Date



ITEM NO. 10 : SIX DOOR LOCKER

QUANTITY : 8 units

ABC / UNIT : Php 15,384.00

ABC FOR THE ITEM : Php 123,072.00

AGENCY'S SPECIFICATIONS	BIDDER'S STATEMENT OF COMPLIANCE	REFERENCE
Brand and Model:		
• Dimension: 88cm W x 51cm D x 178cm H with tolerance of (± 2 cm) in all dimensions		
• Steel, at least Gauge 20		
• With shoe rack, standard size that is commercially available		
• With hanger rod		
• With lock set and padlock		
• Color: Off white or Light Gray		
• Warranty: One year warranty on parts and service		

NOTE: The winning bidder shall submit a sample shade of color or finish before the delivery of item subject to approval of the end-user.

I hereby certify that the statement of compliance to the foregoing technical specifications are true and correct, otherwise, if found to be false either during bid evaluation or post-qualification, the same shall give rise to automatic disqualification of our bid.

Name of Company /
Bidder

Signature Over Printed
Name of Authorized
Representative

Date



ITEM NO. 11 : STEEL CABINET

QUANTITY : 5 units

ABC / UNIT : Php 8,495.00

ABC FOR THE ITEM : Php 42,475.00

AGENCY'S SPECIFICATIONS	BIDDER'S STATEMENT OF COMPLIANCE	REFERENCE
Brand and Model:		
• Dimension: 51" H x 18.5" W x 28.5" D with tolerance of (± 2 ") in all dimensions		
• Steel Cabinet, at least Gauge 20		
• Four (4) drawers with centralized locking mechanism, complete with lock, duplicate keys & card holders and comes with built-in handles		
• Top compartment is with a safe or vault with combination lock, insulated with insulyte perlite powder and cement		
• Lower drawers are fully suspended on local steel bearings, standard and legal size		
• Color: Light gray		
• Enamel painted or powder coated finish still with the same color and material		
• Warranty: One year warranty on parts and service		

NOTE: The winning bidder shall submit a sample shade of color or finish before the delivery of item subject to approval of the end-user.

I hereby certify that the statement of compliance to the foregoing technical specifications are true and correct, otherwise, if found to be false either during bid evaluation or post-qualification, the same shall give rise to automatic disqualification of our bid.

Name of Company /
Bidder

Signature Over Printed
Name of Authorized
Representative

Date



ITEM NO. 12 : **THREE (3) DRAWER LATERAL FILE CABINET**
QUANTITY : **14 units**
ABC / UNIT : **Php 11,495.00**
ABC FOR THE ITEM : **Php 160,930.00**

AGENCY'S SPECIFICATIONS	BIDDER'S STATEMENT OF COMPLIANCE	REFERENCE
Brand and Model:		
<ul style="list-style-type: none"> • Dimension: 900mm W x 450mm D x 1026mm H with tolerance of (±50mm) in all dimensions 		
<ul style="list-style-type: none"> • Three (3) drawers with centralized lock 		
<ul style="list-style-type: none"> • Powder coated Finish 		
<ul style="list-style-type: none"> • Steel plate material, at least gauge 20 		
<ul style="list-style-type: none"> • Color: Beige or Light Gray 		
<ul style="list-style-type: none"> • Drawers are fully suspended on local steel bearings, standard and legal size 		
<ul style="list-style-type: none"> • Handle: Flush recessed 		
<ul style="list-style-type: none"> • Warranty: One year warranty on parts and service 		

NOTE: The winning bidder shall submit a sample shade of color or finish before the delivery of item subject to approval of the end-user.

I hereby certify that the statement of compliance to the foregoing technical specifications are true and correct, otherwise, if found to be false either during bid evaluation or post-qualification, the same shall give rise to automatic disqualification of our bid.

 Name of Company / Bidder

 Signature Over Printed Name of Authorized Representative

 Date



ITEM NO. 13 : MOBILE PEDESTAL

QUANTITY : 54 units

ABC / UNIT : Php 2,884.00

ABC FOR THE ITEM : Php 155,736.00

AGENCY'S SPECIFICATIONS	BIDDER'S STATEMENT OF COMPLIANCE	REFERENCE
Brand and Model:		
• Dimensions: (W) 40cm x (H) 64.5cm x (D) 55.5cm with tolerance of (±1cm) in all dimensions		
• With Three (3) drawers including one (1) central lock, one (1) pen tray, one (1) file divider		
• Material: Steel with powder coating		
• Color: beige / off white		
• With four (4) wheels		
• Warranty: One year warranty on parts and service		

NOTE: The winning bidder shall submit a sample shade of color or finish before the delivery of item subject to approval of the end-user.

I hereby certify that the statement of compliance to the foregoing technical specifications are true and correct, otherwise, if found to be false either during bid evaluation or post-qualification, the same shall give rise to automatic disqualification of our bid.

Name of Company /
Bidder

Signature Over Printed
Name of Authorized
Representative

Date



ITEM NO. 14 : THREE (3) SEATER OFFICE SOFA

QUANTITY : 6 units

ABC / UNIT : Php 34,615.00

ABC FOR THE ITEM : Php 207,960.00

AGENCY'S SPECIFICATIONS	BIDDER'S STATEMENT OF COMPLIANCE	REFERENCE
Brand and Model:		
• Dimensions: at least 2000mm L x 900mm depth with tolerance of (±50mm) in all dimensions		
• Materials and finishes: fabric upholstered, zippered loose seat and backrest cushions. Solid KD wood base in wengue stain finish, semi-gloss lacquer topcoat		
• With left and right side arm		
• With Leatherette Cover, Black in color		
• Warranty: One year warranty on parts and service		

NOTE: The winning bidder shall submit a sample shade of color or finish before the delivery of item subject to approval of the end-user.

I hereby certify that the statement of compliance to the foregoing technical specifications are true and correct, otherwise, if found to be false either during bid evaluation or post-qualification, the same shall give rise to automatic disqualification of our bid.

Name of Company /
Bidder

Signature Over Printed
Name of Authorized
Representative

Date

